

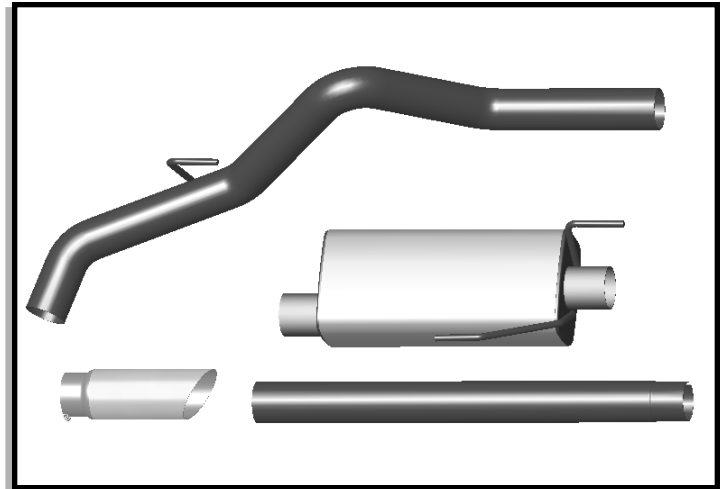

CAT-BACK EXHAUST SYSTEM

87234

2004-05 DODGE RAM P.U.
QC/SB, LB 2/4WD 5.7L HEMI



PARTS INCLUDED

- 1 - Headpipe
- 1 - Muffler Assembly
- 1 - Tailpipe Assembly
- 1 - Chrome Tip
- 3 - 3" Muffer Clamps

TOOLS REQUIRED

- 15mm Box Wrench
- 13mm Box Wrench
- 9/16" Box Wrench
- 9/16" Socket
- Hacksaw or Equivalent
- WD40 or Equivalent

INSTALLATION INSTRUCTIONS

BEFORE STARTING:

- 1) Gather all appropriate tools and secure a clean work space.
- 2) Read instruction sheet completely. If you have any questions, call our tech. department at (951)739-5900.
- 3) Do not cut or modify parts unless instructed to do so.
- 4) Always disconnect the battery when working on your vehicle to avoid any potential problems.
- 5) Your vehicle should be raised to ease installation. A hoist is ideal, however, installation can be accomplished using a floor jack and jack stands. **CAUTION:** Never work on a vehicle that is supported by a bumper jack only.
- 6) Although muffler clamps are provided, they are only intended to temporarily hold the system together until it can be fully welded.

REMOVAL/ASSEMBLY:

- 1) Starting at the rear of exhaust, spray WD40 or equivalent lubricant on the rubber hangers to allow easy removal of all hanger rods.
- 2) Loosen the muffler clamp on the stock headpipe. Slide the hanger rods out of the stock rubber hangers. Save all of the rubber hangers as you will reuse them on your new system.

PERFORMANCE DELIVERED!

QUESTIONS: (951)739-5900

CAT-BACK EXHAUST SYSTEM

87234

2004-05 DODGE RAM P.U.
QC/SB, LB 2/4WD 5.7L HEMI

- 3) Lower the front of the stock system and slide forward over the rear axle. **NOTE:** To ease the stock system removal it will be necessary to cut the stock system in several places.
- 4) Begin by installing the new headpipe and muffler assembly using the supplied muffler clamp and original rubber hangers. Do not fully tighten the muffler clamp to allow for proper positioning.
- 5) Install the new tailpipe over the axle and slide into the rear of the muffler. Slip hanger rods into original rubber hangers. Install 3" muffler clamp loosely on the rear of the muffler.
- 6) After checking for proper system clearance and alignment, tighten all the u-clamps. Install provided chrome tip and tighten pinch bolt when satisfied with proper positioning.
- 7) Reconnect battery and start vehicle, checking for any exhaust leaks or rattles - adjust system as necessary. After several days driving time, recheck all bolts tightness.

FULL ASSEMBLY

