

2005-09 NISSAN/ SUZUKI EC,CC/SB
FRONTIER/ EQUATOR, 4.0L, 2/4WD

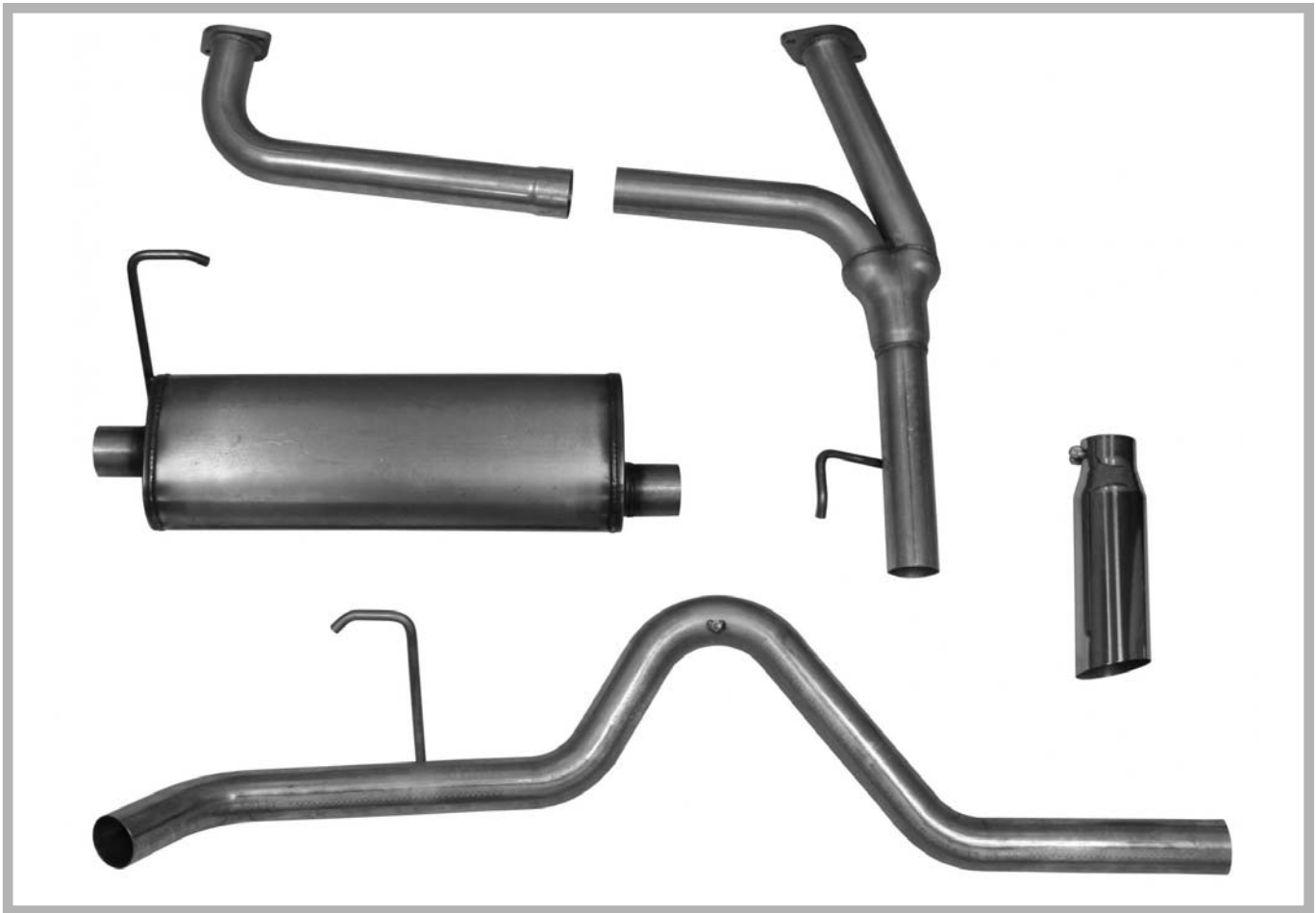

PARTS INCLUDED

Ref.	Description	Qty
1)	Passenger side Y-pipe Assembly	1
2)	Driver side connector pipe Assembly	1
3)	Muffler Assembly	1
4)	Tailpipe Assembly	1
5)	Chrome Tip	1
6)	2-1/2" Muffler Clamp	2

08-50-44630 REV. B

CAT-BACK EXHAUST SYSTEM

83205

2005-09 NISSAN/ SUZUKI EC,CC/SB
FRONTIER/ EQUATOR, 4.0L, 2/4WD

TOOLS REQUIRED

Ref.	Description
1)	9/16" Socket
2)	13mm Wrench
3)	15mm Wrench

Ref.	Description
5)	9/16" Wrench
6)	Hacksaw or Equivalent
7)	WD40 or Equivalent

INSTALLATION INSTRUCTIONS

BEFORE STARTING:

- 1) Gather all appropriate tools and secure a clean work space.
- 2) Read instruction sheet completely. If you have any questions, call our tech. department at (951)739-5900.
- 3) Do not cut or modify parts unless instructed to do so.
- 4) Always disconnect the battery when working on your vehicle to avoid any potential problems.
- 5) Your vehicle should be raised to ease installation. A hoist is ideal, however, installation can be accomplished using a floor jack and jack stands. **CAUTION:** Never work on a vehicle that is supported by a bumper jack only.
- 6) Although muffler clamps are provided, they are only intended to temporarily hold the system together until it can be fully welded.

REMOVAL/ASSEMBLY:

- 1) Starting at the rear of exhaust, spray WD40 or equivalent lubricant on the rubber hangers to allow easy removal of all hanger rods.
- 2) Unbolt flange from the stock headpipe. Slide the hanger rods out of the stock rubber hangers. Save all of the rubber hangers and hardware as you will reuse them on your new system.
- 3) Lower the front of the stock system and slide forward over the rear axle. **NOTE:** To ease the stock system removal it will be necessary to cut the stock system in several places.
- 4) Always disconnect the battery when working on your vehicle to avoid any potential problems.

CAT-BACK EXHAUST SYSTEM

83205

2005-09 NISSAN/ SUZUKI EC,CC/SB
FRONTIER/ EQUATOR, 4.0L, 2/4WD

- 5) Begin by installing the new passenger Y-pipe assembly into the stock rubber hanger and bolt to the stock system using the original hardware and gasket. Slide the driver side connector pipe into the Y-pipe and attach with a supplied 2-1/2" clamp. (See **Figure 1**) Do not fully tighten the muffler clamp to allow for proper positioning. Then re-install grounding strap and bolt to the stock system using original hardware and gasket.

Figure 1

- 6) Slide the muffler assembly over the Y-pipe and install 2-1/2" muffler clamp loosely between

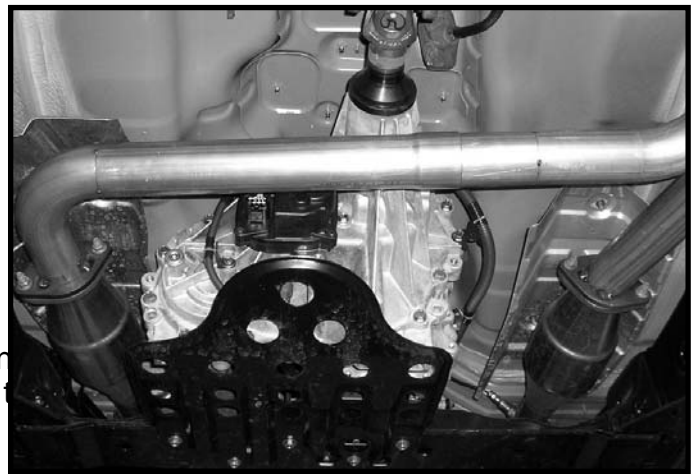

CAT-BACK EXHAUST SYSTEM

83205

2005-09 NISSAN/ SUZUKI EC, CC/SB
FRONTIER/ EQUATOR, 4.0L, 2/4WD

- 7) Install the new Tailpipe assembly over the axle and slide into the rear of the muffler. Slip the hanger rod into original rubber hanger. Install 2-1/2" muffler clamp loosely on the rear of the muffler. Re-install grounding strap using the stock nut. **(Shown Below)**



- 8) After checking for proper system clearance and alignment, tighten all the U-clamps. Install provided chrome tip and tighten pinch bolt when satisfied with proper positioning.
- 9) Reconnect battery and start vehicle, checking for any exhaust leaks or rattles - adjust system as necessary. After several days driving time, recheck all bolts tightness.

Full Assembly View

